

1

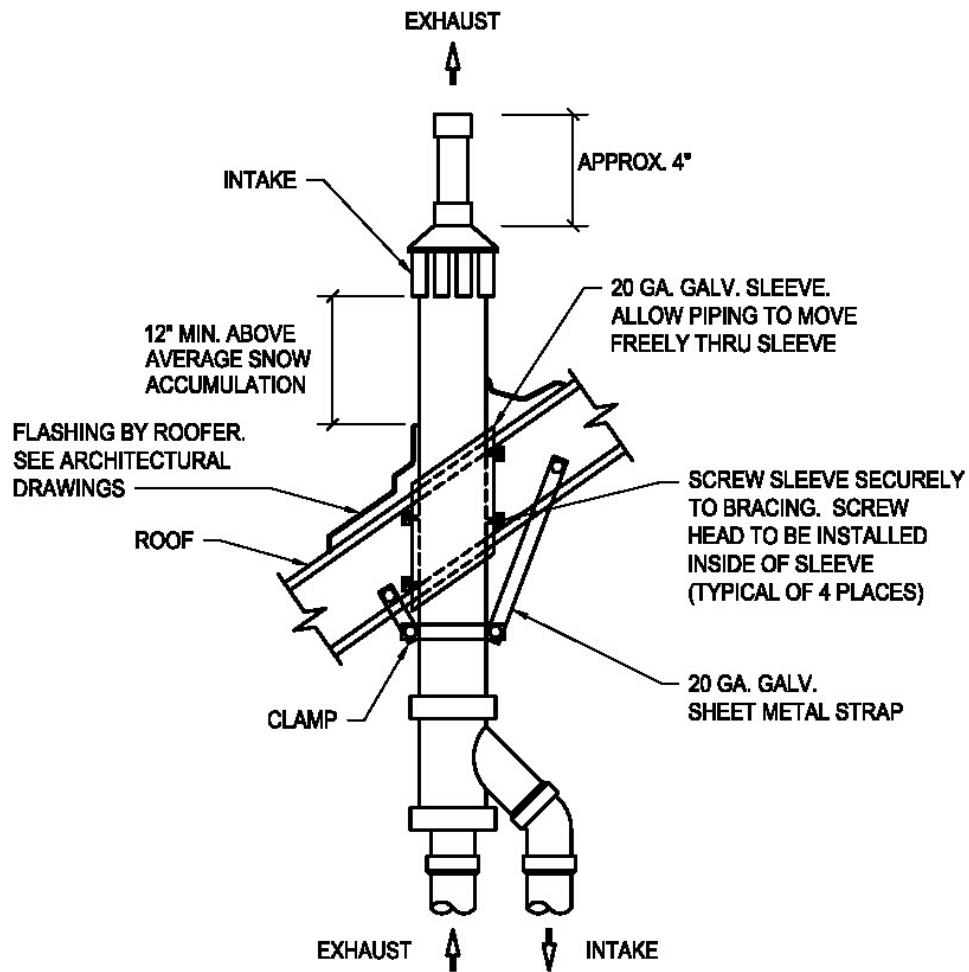

9
M501

CONCENTRIC ROOF TERMINATION DETAIL

NO SCALE

ADDENDUM # 2 - APPENDIX 'C'
REFERENCE: M501



Hayes Design Group
ARCHITECTS

100 Ryan Court, Suite 11
Pittsburgh, PA 15205
Phone: 412.206.0410

WOODSTOCK WARD

Project No.:1608

04/05/17

MSK-01